





Energy Solutions for Business Growth

● www.starkenergyghana.com

Innovative Engineering Company

Stark Energy Limited is an innovative Ghanaian engineering company focused on providing tailor-made advanced engineering solutions for the downstream, midstream and upstream oil and gas companies in Ghana and neighbouring countries. The creation of Stark Energy stems from the demand for professional business and engineering services in the area of technical design, Asset Integrity, HSEQ (Health, Safety, Environment and Quality) as well as advanced solutions in the oil and gas industry. Also, Ghanaian-owned and foreign industries are constantly seeking assistance to meet the permitting requirement of most Regulatory bodies and Stark Energy strives to aid them meet the criteria for the issuance of such Permits and Licenses. Stark Energy is licensed to provide Asset Integrity services in Ghana's upstream oil & gas sector.

Stark Energy is the country representative of MANNTEK-Sweden, ELAFLEX-Germany, FAUDI Aviation & Diesel-Germany, PARLYM-France, DEC-Belgium and EM&I-UK in Ghana. For the Upstream & Midstream Petroleum Sector

and Renewable Energy Industries, in partnership with EM&I, Stark Energy provides Asset Integrity Management, Inspection, and specialised Repair & Maintenance services.

We provide the following services for our clients:

- ✓ Asset Integrity Management of Floating Production Storage and Offloading (FPSO), Mobile Offshore Drilling Units (MODUs), Floating Storage Regasification Units (FSRUs), Floating Liquefied Natural Gas (FLNG) and Onshore Petroleum Assets.
- ✓ Technical Consultancy Services for downstream Petroleum Processing Plants.
- ✓ Business Plan.
- ✓ Petroleum Licenses and Permit Documentation.
- ✓ Petroleum Plant Designs.
- ✓ Engineering software services including: DMS, PDS, SP3D, AUTOCAD, Spoolgen etc.

- ✓ Process Simulation for both 2D drafting and 3D modelling for projects
- ✓ Provision of PFDs, UFDs and P&IDs for Petroleum Processing Plants.
- ✓ Conceptual Design, Basic Engineering Design, Front End Engineering Design and Detailed Engineering Design.
- ✓ Health, Safety & Environment.
- ✓ Energy Management.
- ✓ HAZOP (Hazard Operability Studies).
- ✓ Engineering Drawing for Petroleum Processing Plants.
- ✓ Feasibility Studies.
- ✓ Engineering, Procurement, Construction & Installation in partnership with PARLYM and DEC
- ✓ Mobile Equipment for Hydrotesting of Petroleum Hoses.
- ✓ Assembly, Repair, Testing & Certification of Petroleum Hoses.

About Us

We provide bespoke engineering solutions for our clients through a systematic approach and thorough examination of our client's operations, facilities, and technologies. Based on our extensive knowledge coupled with skilled expertise in process engineering, energy management, health and safety, oil and gas services among others, we deliver the optimal and innovative solutions to ensure that the best practices are incorporated into their operations.

Our team of experts is well-versed in the provision of technical services for oil and gas processing plants; thus, we employ a unique approach in the delivery of engineering solutions that emphasizes our ability to expressly and efficiently meet the needs of our clients.

Vision

To be the Ghanaian and West African leader in delivering tailor-made advanced engineering solutions by nurturing talented, dedicated, and committed teams that work with openness and integrity.

Mission

Stark Energy delivers tailor-made advanced engineering solutions for the oil & gas and renewable energy industries.





Efficient Convenient & Reliable

We deliver to you the convenience
that provides speed and efficiency
in your productivity

Stark Energy Services



Consultation



Health, Safety
& Environment



General
Contractors
(EPC)



Conceptual
Designs



Engineering software
services including:
PDMS, PDS, SP3D,
AUTOCAD,
Spoolgen etc.



Process Simulation
for both 2D drafting
and 3D modelling
for projects



Asset Integrity
Management



Petroleum
Plant Design



Feasibility
Studies



Energy
Management



HAZOP and
HAZID Studies



Business
Plan



Assembly of Hoses
and Hydrotest



Petroleum
Licenses & Permit
Documentation



Engineering
Drawing



Servicing of
Valves

Engineering and Technical Consultancy Services



Stark Energy provides its clients with a close support service, choice of solutions and consultancy services in the following areas:

- 1**
Hazard and Operability (HAZOP) Studies
- 2**
Hazard Identification (HAZID) Studies
- 3**
Oil and Gas Incident Prevention Management
- 4**
Systems Thinking in Organizations
- 5**
Asset Integrity Management
- 6**
Systems Architecture
- 7**
OPEX Reduction
- 8**
Consultation Services on Selection and Provision of Power Generators
- 9**
Operations and Maintenance Policy for Optimum QoS and asset life span
- 10**
Technical Support with Offshore Engineering services such as Design and engineering of offshore platforms, jackets and top-sides, Design, engineering and analysis of skids and modular structures , Stress and fatigue analysis of structures using finite element analysis using softwares like PDMS, STAAD-Pro, SESAM, SACS, ANSYS, MATHCAD.
- 11**
Technical Support with Provision of Engineering software services including: PDMS,PDS,SP3D, AUTOCAD, Microstation, CEASAR-II, Spoolgen etc.

Health & Safety

The ongoing industrialization of the Ghanaian economy is calling for a renewed focus on health and safety issues across various sectors of the Ghanaian economy. This rate of industrialization has called for a renewed request for business operators to take a critical look at health and safety issues across the organizational spectrum. Health and Safety, which hitherto was not such a critical subject in the Ghanaian economy, is now assuming an imperative role in Ghana. Most Ghanaian industries do not have health, safety, and environmental officers and therefore, do

not adhere to safety standards. This has resulted in an increased incidence of accidents and personal injuries at the workplace.

Stark Energy Limited has extensive experience in the development of HSE management systems, safety management policies and programs, coordinating training programs, incident investigation, auditing of management systems, and Risk assessment in the power and oil & gas sectors. In addition to this, Stark Energy helps our clients develop the following;



1. HSE Management Systems
2. HSE Policy Statement
3. Site Rules
4. Emergency Preparedness Plan
5. Emergency Evacuation Plan
6. Drug and Alcohol Policy
7. Personal Protective Equipment
8. Incident Investigation and Reporting
9. Oil and Gas Incident Prevention Management
10. Environmental and Waste Management Plan

11. Environmental Aspects Register
12. Environmental Care Policy
13. Safety Signs
14. Fire Prevention Plan
15. Carriage of Hazardous Goods
16. Risk Assessment Plan
17. First Aid Practice
18. Contractor Management
19. Visitors Guide

Stark Energy Limited is well positioned to assist business start-up and foreign companies with various health and safety policy options that will guarantee a safe working environment.

Energy Audit

The utilization of energy is a key issue of interest in all industrial sectors because of its impact on the cost of production. At Stark Energy, we carry out audits on industries and facilities to ascertain the performance levels of installed equipment as well as their overall processes and respond more effectively to any identified weaknesses.

We help customers to increase the efficiency of their equipment and processes by including energy-efficient specifications such as heat recovery

options among others and identifying losses and providing solutions to minimize such losses.

Audits carried out by Stark Energy are comprehensive and help the customer/client to obtain information on their systems for the improvement of their processes. Our audits provide in-depth knowledge of energy consumption in industries, facilities, and buildings.

In addition to this, we help our clients in the development of the following:



1

Defined scope of audit

Pre-Audit Stage

2

Gather Preliminary Data

3

Site inspection and Data Collection

4

Reporting

5

Monitoring and Review

Energy Audit Stage

Post-Audit Stage



Energy Management

Fluctuating fuel costs and the fuel market have undermined the efficient use of energy in most industries. At Stark Energy, we come up with energy management systems to assist businesses with the efficient use of energy. We also help businesses to maximize their profit margins through the judicious use of energy by developing and sustaining effective monitoring, reporting, and management strategies for the efficient use of energy.



Energy Management Systems



Maximize Profit margins



Strategize for Business Growth

Business Plans, Feasibility Studies and Conceptual Design

We provide services that comprise business plans, feasibility studies and give definitive engineering direction to our clients on their intended projects. When it comes to feasibility studies, we study and evaluate the potential for success of every project and choose the best path to be followed. We can identify the types of risks facing each project by carrying out a concise risk assessment, also taking into consideration viable options for success as well as identifying project alternatives.



Our vast experience in the preparation of business plans, feasibility studies, and award-winning proposals makes us the best company to deal with.

We offer conceptual engineering services for the generation of technical solutions. Under this, we provide end-to-end engineering and design services ranging from re-design to technical documentation such as:

1. Process Flow Diagrams (PFD)
2. Piping and Instrumentation Drawings (P&ID)
3. Utilities Flow Diagrams (UFD)
4. Process Descriptions
5. Standard Operating Procedures (SOP)
6. Conceptual Design, Basic Engineering Design (BED), Front End Engineering Design (FEED) and Detailed Engineering Design (DED) of Petroleum facilities according to ASME, ANSI, API, ASTM, NFPA and BS_EN Standards
7. Cost Estimation
8. Scheduling



Engineering, Procurement, Construction and Installation in partnership with PARLYM and DEC

We undertake contracts in the engineering, procurement and construction of systems as well as installations for industries, commercial based centers, SME. These include:

- Selection and Installation of Energy efficient Heating System
- Selection and Provision of Cooling Systems
- Installation of Pumps, Compressors, turbines, etc.
- Insulation works
- Selection and provision Pumps and Motors

Energy Based Products and Services for Commercial business Centers, SME, Real Estates, Small Hotels, Medium Hospitals, Fast foods, Small Shopping Malls etc.

- Provision of Auto Change Over and Critical Load back up Device
- Provision and Selection of UPS systems
- Selection and Installation of Energy Efficient Refrigeration & Air conditioners (Central & Split systems)
- Provision of Installation Standards and appliance selection Services (Mechanical & Electrical)
- Provision & Selection of Voltage stabilizers

Engineering, Procurement, Construction, Installation & Commissioning of Petroleum Facilities

- Preparation of Process Flow Diagrams (PFD)
 - Preparation of Piping and Instrumentation Drawings (P&ID)
 - Preparation of Utilities Flow Diagrams (UFD)
 - Preparation of Process Descriptions
 - Preparation of Standard Operating Procedures (SOP)
 - Preparation of Conceptual Design, Basic Engineering Design (BED), Front End Engineering Design (FEED) and Detailed Engineering Design (DED) of Petroleum facilities
 - Petroleum facilities Construction & Commissioning Construction of AGO, PMS, LPG & base oil storage tank farms.
 - Provision of Fuel Regulators (Control Devices) for LPG and Natural gas
-

Stark
Energy
Products
MannTek,
ELAFLEX
& FAUDI
AVIATION
and DIESEL
FILTRATION

All your needs concerning MannTek,
ELAFLEX, and FAUDI Aviation &
Diesel Filtration Products





The Sole Representative and Distributor

of MannTek Products in Ghana
and neighbouring countries

MannTek

The World's widest Range of Dry Disconnect Couplings

1

Dry Disconnect Couplings

Dry Disconnect Couplings are the given choice for handling any liquid, chemicals, gas etc.



2

Dry Aviation Couplings

Dry Aviation Couplings are designed for use in aviation and military refuelling systems with a maximum working pressure of 10 bar (150 psi).

3

Dry Gas Couplings

Dry Disconnect Couplings are the given choice for handling any liquid, chemicals, gas etc.



4

Safety Break-away Couplings

Safety Break-away couplings are used to prevent pull away accidents, protect terminal and loading/unloading equipment and eliminated unwanted product release.



5

Dry Evotek Couplings

DEC – Dry Evotek Couplings stands for another generation of dry disconnect couplings, that is specially made for use in the chemical industry.



6

Full Flow Ball Valves

Full flow ball valves and 2-way ball valves are specially designed for handling different types of fuels such as diesel, gasoline, jet fuel etc.



SCAN for more about
MannTek Products



Completed Deliveries



1

Supplied Dry Disconnect Couplings to GTS Semi-Trailers for use at the Kotoka International Airport



3

MannTek Dry Gas Couplings in use at Matrix LPG loading terminal in Tema

2

Dry Gas Couplings installed at all LPG Bulk Distribution Companies (Quantum, Matrix and TFC) in Ghana



4

Dry Aviation Coupling to Puma Energy for Aircraft Aviation Refueling at the Kotoka International Airport





The Sole Representative and Distributor

of ELAFLEX Products in Ghana
and neighbouring countries



1

Hose Fittings

Our main strength lies in fittings for petroleum-based products and chemicals, main areas of use are in petrol stations, rail and road tankers.



3

Nozzles + Spare Parts

Due to its modular system all major parts can be replaced. ZVA are suitable for every petrol dispenser, every hose and every vehicle filler neck. Additional retrofitting in the field is trouble free.



2

Petrol + Chemical Hoses

With hoses from ELAFLEX you simply make the right choice. As they are used for dangerous goods we acknowledge responsibility for our products.

4

Rubber Expansion Joints

ERV FOR FLEXIBLE CONNECTIONS. Rubber Expansion Joints (compensators) are used as flexible connectors within pipe systems



5

Tank + Pipe Fittings

Can be mounted to hose assemblies, pipe systems, tanks and road or rail tankers. Additionally we offer a large range of adapters, caps and plugs, swivels, flanges with thread, welding flanges, sight glasses, and spare seals.



SCAN for more about ELAFLEX Products



Completed Deliveries



1

Distributed ELAFLEX LPG hoses to all LPG bulk distribution companies (Quantum, Matrix, TFC) for use at their LPG loading terminal in Ghana

2

Delivered ELAFLEX Composite hoses to Tema Fuel Company to be used for inter-transfer of products from one tank to another

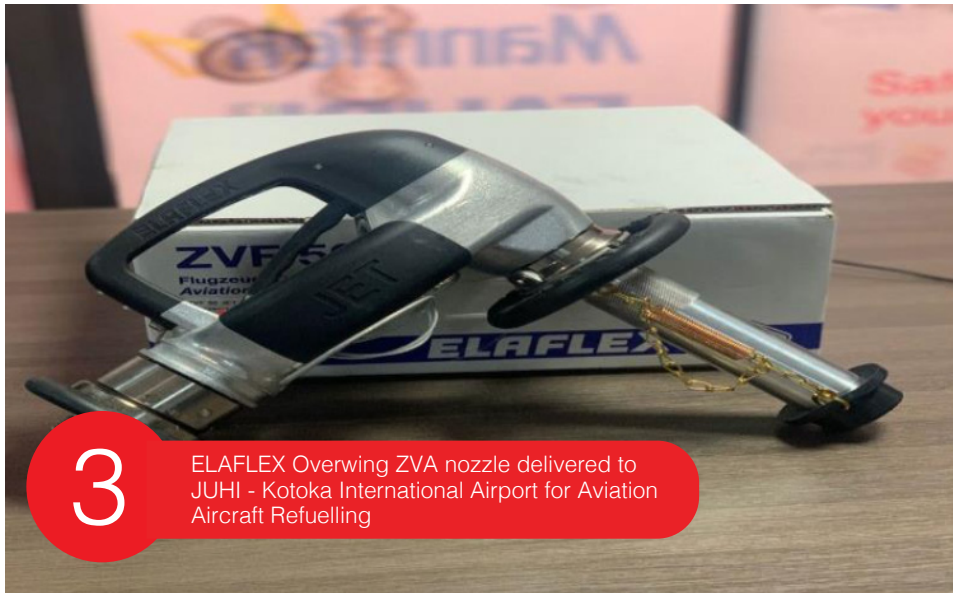

3

ELAFLEX Overwing ZVA nozzle delivered to JUHI - Kotoka International Airport for Aviation Aircraft Refuelling

4

Supplied LPG hoses to Tema Fuel Company to be used at their LPG loading gantry



Completed Deliveries



5

ELAFLEX hoses delivered to IBISTEK for use at Takoradi Oil Jetty

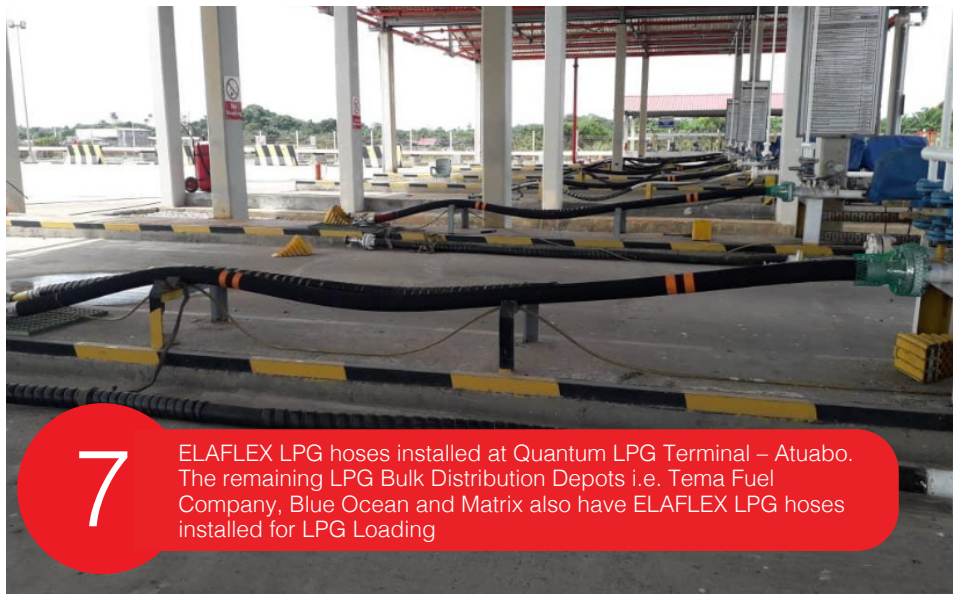

7

ELAFLEX LPG hoses installed at Quantum LPG Terminal – Atuabo. The remaining LPG Bulk Distribution Depots i.e. Tema Fuel Company, Blue Ocean and Matrix also have ELAFLEX LPG hoses installed for LPG Loading

6

Constant supply of ELAFLEX ZVA Nozzles and Safety Breakways to major service companies like Universal Engineering, Rich Morgan, and GPS Tokheim for use at TOTAL, SHELL, GOIL and other OMCs Fuel Dispensing Stations



8

Installed ELAFLEX CAMLOCK Assembly on selected Bulk Road Vehicles for TOTAL Ghana for specialized operations



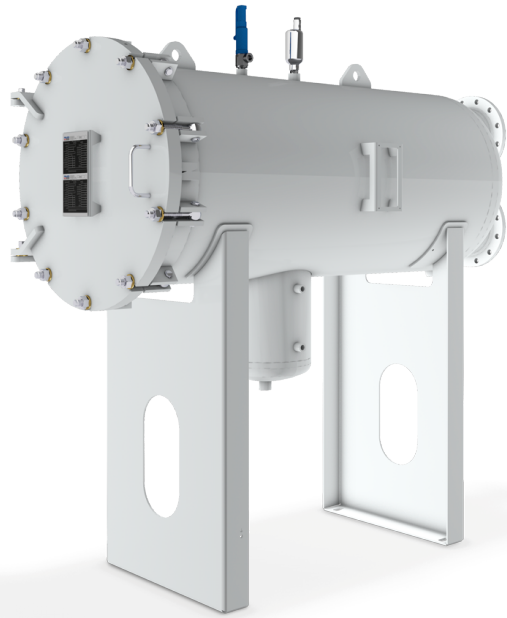

The Representative and Distributor

of FAUDI Aviation and Diesel
Filtration in Ghana



1

Filter Water Separator

Filter/water separators consist of a two-stage system designed to remove free water and particulates from diesel fuels in refineries, terminals, fuel depots, tankers, hydrant dispensers and refueling equipment.

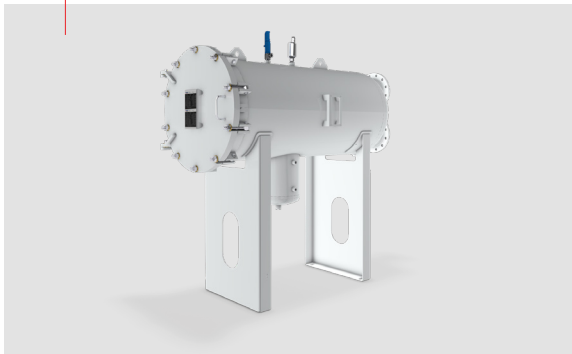

2

Coalescer Element

Coalescer elements are designed to coalesce free water and to remove fine solids from diesel fuels. Coalescers are deployed at the first stage in a filter/water separator, when fuel enters the vessel.

3

Separator Elements

Separator elements are used as the second stage of a high-performance separation in filter/water separators. After emergence from the coalescer, aviation fuels pass through the pores of the separator element while water droplets are repelled by the hydrophobic separator surface.

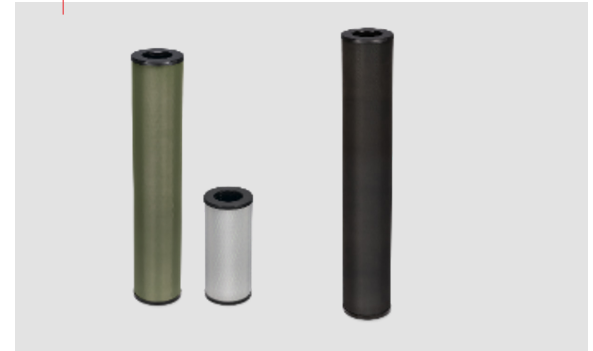

4

Sensors and Controllers

Electronic sensor for the detection of free water in diesel fuels. The sensor is qualified for use as an alternative to Chemical Water Detectors (CWD). The sensor is considered fail-safe. The controller System for automatic calculation of corrected differential pressure measurement in refuelling applications.



5

Micronfilters

Micronfilters are used as pre-filters for the efficient and continuous removal of solids such as rust, sand and other particulates from aviation fuels. FAUDI Diesel micronfilters are used in refineries, terminals and airport depots, primarily as prefilters to lengthen the service life of downstream coalescer elements in filter/water separators.



More than **1,000**
employees, experts in
engineering, consulting
and technical
assistance.

In order to support the energy transition by bringing together the expertise and convictions of its employees, Parlym carries out energy infrastructure projects for its clients in the nuclear, oil & gas and renewable energy sectors.



Country Representative

OF PARLYM



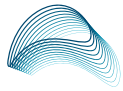

Completed EPC Projects

1

EPC, in the form of a supplier credit, for the construction of the multi-products hydrocarbon storage plant of 24,000m³



2

EPC, in the form of a supplier credit, for the rehabilitation and extension of the hydrocarbon storage plant of 60,000m³ in Yamoussoukro.



3

EPC for the construction of 4 LPG storage and bottling plants with two spheres of 2,200T each, in Mongla / Dhaka / Bogra / Chittagong. Construction of a LPG river barge of 300T.



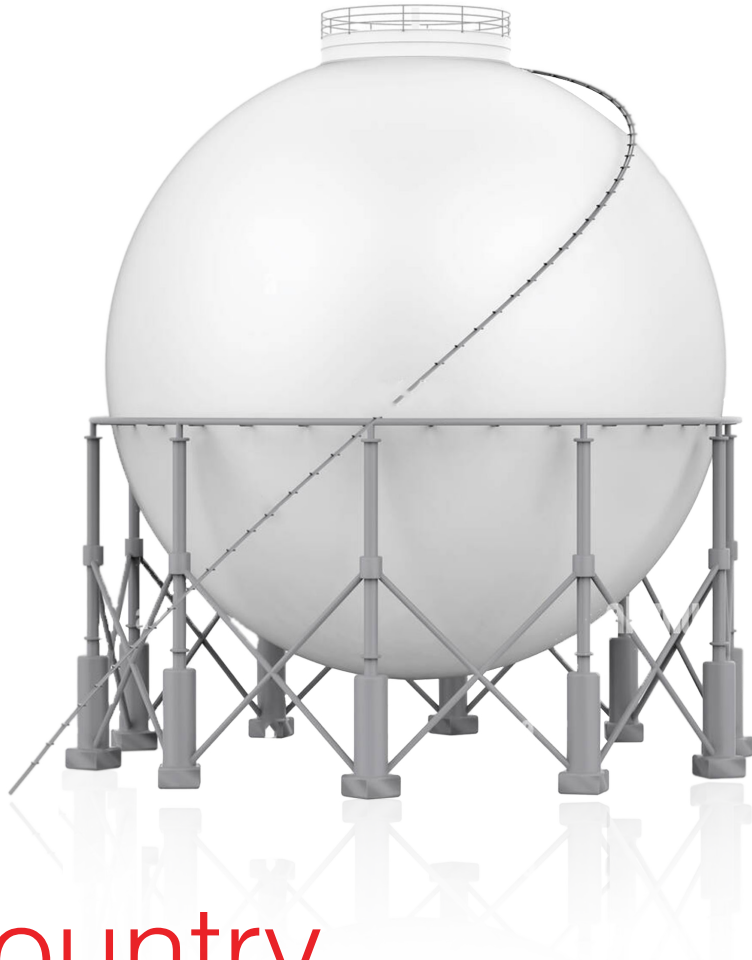

Country Representative

of Design Engineering
& Consulting



Completed EPC Projects

1

PETROMAX LPG, Mongla, Bangladesh

1 LPG sphere 3,000 m³ & 2
LPG spheres 4,000 m³



2

EUROGAZ LPG – LPG import terminal & bottling plant, Chittagong.

30,000 T/y 2 LPG spheres of 3,500 m³



3

EUROGAZ LPG – LPG import terminal & bottling plant, Chittagong.

1 LPG storage sphere of 3,000m³
& 2 LPG bullet tanks of 120m³ each,
Cylinder bottling facilities, Truck loading
post, Fire-fighting system & SCADA system.





Country Representative

Of EM&I



Completed Projects



TULLOW's JUBILEE FPSO

- Provision of LIMPET Sea Chests Isolations.
- Remotely Operated Vehicle (ROV) Special survey of the hull and its appendages (General Visual Inspection (GVI)/Close Visual Inspection (CVI) and Angle Measurements).
- Cathodic protection Surveys.
- Isolation and monitoring of underwater penetrations and discharge lines.

1



ENSCO 5004 FPSO – ENSCO/VALARIS

- ODIN Alternative UWILD
- ODIN Valve Isolation on Valve Repair
- NoMan Services
- Topsides Structural Inspections
- Installation of Inspection Hatches
- ODIN (Repair of jetting pipe lines)
- ODIN Inspection
- ODIN UWILD and SPS Survey

2



KIZOMBA FPSO – EXXONMOBIL

- Asset integrity Management Services
- Inspection Management
- Engineering Support
- Condition Monitoring
- NDE Services - UT, MPL, LPI, Digital/Real Time Radiography
- Population of Meridium database for inspection and anomaly management
- Use of SAP for Planned Maintenance inspections and Meridium Interface
- Provision of Fabric Maintenance Services
- Cathodic Protection Surveys
- Failure Analysis
- Fitness for Service Assessments
- Rapid detection of CUI
- Caisson Cleaning and Thickness Measurement
- ODIN UWILD

3

Completed Projects



SOYO LNG PLANT – ANGOLA

- Provision of Onshore integrity Management Services
- Development of Process Pressure Equipment Risk Based Inspection system
- Risk Based Assessment of Pressure Systems
- Corrosion Risk Assessment and Criticality Analysis
- Set-up, Population and Periodic Reviews of Integrity Database
- Development of Baseline Strategy
- Site Inspection / NDT Services
- Failure Investigation

4



BLEO HOLM FPSO – BLUE WATER ENERGY SERVICES

- Provision of Integrity Management for the Hull and Topsides
- Inspection and Survey Services and Structural Repairs
- NDE Services - UT,MPL,LPI,EC,TOFD,Weld Root, Class Surveys, Mass/ CYCLOPS CCTV, MOLE
- Other Services - Structural Steel Repairs, Piping Repairs, Coating Repairs, Corrosion Protection, IGL00 Hotwork Habitats, TOPCAT Staging

5



ARMADA CLAIRE FPSO – BUMI ARMADA

- Provision of Asset integrity Services
- Inspection and Survey Services
- NDE Services - UT,MPI,LPI,EC, Class Surveys
- Other Services - Structural Steel Repairs,IGL00 Hotwork Habitats
- Fitting ODDIN Access Ports
- Provision of ODDIN Valve inspection
- Inspection of Sea Chest Valve

6



MOBILE HYDROTEST EQUIPMENT

For Hoses







MOBILE HYDROTEST EQUIPMENT FOR HOSES

Stark Energy Limited has ventured into mobile hydrotest equipment for hoses. We have been certified by the Factories Inspectorate to conduct this hydrostatic test. The test will involve filling a hose with water and taking it to a pre-specified test pressure. While the test is going on, there are checks for leaks and expansion. After the hydrotest of a hose, there is also a test for electrical continuity to ascertain that the hoses are able to dissipate the required electrostatic charges. Every single tested hose assembly is identified with a sticker label which contains coded test date, test pressure, electrical resistance and the next test date.

This information is recorded on the test certificate issued to clients after each test. Our test is conducted with a hydraulic test pump assembly as shown below, which can generate up to 29 bar test pressure. We can guarantee that if a hose passes our test, then it is safe to use for the next six months without bursting.

Stark Energy has successfully conducted Hydrotesting, Inspection & Certification of Hoses for LPG BDCs & Depots including Tema Fuel Company, Quantum, Annadale Gas and Xpress Gas. Test Certificates as shown on the right-hand side are duly issued after completion of the Hose inspection and testing.

1. Hose hydrotest
2. Electrical Continuity test
3. Hose Sticker Label
4. Hose Certification
5. 6 months Guarantee



HOSE PRESSURE TEST & INSPECTION CERTIFICATE

Client: Xpress Gas Limited (Lomotex Gas)
Goaso

Certificate Number: STARK/INS/00029/22
Order No.: STARK/ORD/00009/22
Date: 20/09/2022

PRODUCT DETAILS

JOB NUMBER	STARK/ORD/00009/22/5	HOSE CODE	LPG 50
HOSE NOMINAL BORE	2"	HOSE LENGTH	8 m
FITTING 1	2" NIPPLE	FITTING 2	2" NIPPLE
TEST PRESSURE	11 barg	NORMAL OPERATING PRESSURE	7 barg
DATE OF TESTING	20/09/2022	ELECTRICAL CONTINUOUS RESISTANCE (Ohms)	03

TEST METHOD

HYDRAULIC TEST MEDIUM: WATER | **TEST PERIOD:** 15 MINS

Pressure Test:
Above items were tested at 11 bar / 15 mins. Test medium water. No leakages or faults were found.

Electrical Continuity:
The electrical continuity was tested. The electrical resistance between the couplings, measured at the couplings, was recorded as: **03 Ohms**

Physical Inspection:
Physical inspections were conducted on the hose and no visual cracks were found.

INSPECTOR NAME: THEOPHILUS KWABENA DADZIE
SIGNATURE: 
DATE: 20/09/2022

Certified by Ing. Dr. Papa Benin - GbIE Reg. #: 06559 & ASME Reg. #: 100000752
SIGNATURE: 

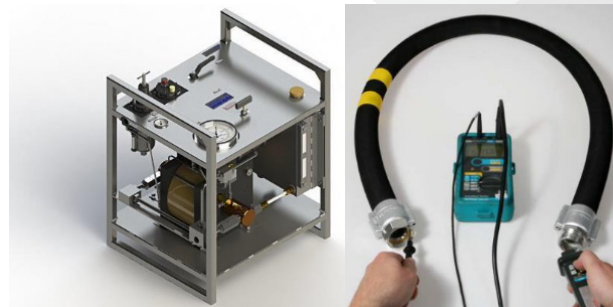

Stark Energy's Projects

1

6,000 BPSD Akwaaba Oil Refinery Project, Ghana

Consultancy services for Akwaaba Link Investment Limited's Oil Refinery (Provision of HSE services, PFDs, P&IDs, and SOP development). Provision of all the required documentation to NPA that led to the issuance of Refinery Permit to Operate certificate.

2

Greenwich Industries Limited Waste Lube Oil Recycling Plant, Ghana

Provision of Consultancy services for Greenwich Industries Limited – Waste Lube Oil Recycling Company. (Provision of HSE services, PFDs, P&IDs, and SOP development). Provision of all the required documentation to NPA that led to the issuance of Processing Plant Permit to operate certificate.

3

PSB 50,000MT AGO, 30,000MT PMS and 10,000MT LPG Storage Tank Farm

Technical Services Consultants to PSB's 50,000 mt AGO, 30,000 mt PMS and 10,000 mt LPG Storage Tank Farm and Automated Loading Gantry Project.

4

Sahara Group's 6,000mt LPG Storage Facility

Technical Services Consultants to Sahara Group-Ashrami Synergy Ltd's 6,000 MT LPG Storage Facility and Associated Loading Gantry Project.

5

300,000 BPSD Ada Oil Refinery

Preparation of NPA Required Documentation for the acquisition of License for the construction of a 300,000 BPSD Crude Oil Refinery at Ada, Ghana.

Rikpat's 20 TON/HR Lube Oil Blending Plant

Stark Energy provided the following technical services; Provision of HSEQ (Health, Safety, Environment, and Quality) services and documentations, produced required documentation for the acquisition of National Petroleum Authority (NPA) License and permit for construction of the lube oil blending facility, supervised construction and installation of capital assets, provision of complete PFDs, UFDs, P&IDs, and SOPs for the entire refinery, supervised the commissioning and test run of the facility and submitted the test run to NPA and produced NPA required documentation, which led to the issuance of Permit to Operate the Lube Oil Blending Plant.

6

7

Metka's Combined Cycle Power Plant, Ghana

Stark Energy Limited undertook HAZID Constructability Risk Assessment for the 3.5 Km Natural Gas Pipeline Construction from the VRA Natural Gas Substation to Metka's Power Plant in Tema.

130 MW Solar Power Plant in Ghana

Stark Energy Limited is the consultants to Orion Energy Ghana/ Petra's 130 MW Solar Power plant and provide all technical, administrative and operational support to ensure that the renewable project is developed. Stark Energy Limited will also be providing technical and operational support before, during, and after the construction of the project.

8

9

Installation and Commissioning of Tank Gauging and Gas Detection Systems at Quantum, Tema

- Mounting of sets of tank instruments for 3 No. LPG tanks.
- Loop checking to confirm existing wiring on all terminations.
- Termination of instruments in the field and MCC room (RTU).
- Final loop checks and instruments power up.
- Functional checks and handing over.
- Submission of installation report.

Provision of Electrical, Instrumentation, Fire and Gas Systems and SCADA Installation works at the Newgas Cylinder Bottling Plant, a subsidiary of the Quantum Group - Tema

10

1. Installation of Low Voltage (LV) switch board with Automatic Transfer Switch (ATS).
2. Connection of power cables and control cables from LV Switchboard to field equipment.
3. Installation of pressure gauges, flow switch and emergency shutdown valves.
4. Installation of instrument junction box and support.
5. Installation of field Fire and Gas (F&G) devices including; Flame detectors, Gas detectors, Heat detectors smoke detectors, manual call point, beam and sounder.
6. Installation of Fire and Gas panel.
7. Connection of electric cables from F&G terminal server to field F&G devices including termination.
8. System wiring between F&G terminal server and F&G panel.
9. Installation of SCADA & KC SCADA panel.
10. Wiring and connection of cables between SCADA & KC SCADA panel.
11. System wiring between Remote Terminal Unit (RTU) terminal server and RTU.
12. Connection of cables between RTU and F&G panel.
13. Calibration of field instruments.
14. Test and inspection as per Electrical continuity check, loop check and others.

Special Survey, LIMPET Sea Chest Isolations And Remotely Operated Vehicle (ROV) Inspection On Tullow's Jubilee FPSO, GHANA

11

1. Installation of the LIMPET Sea Chest Isolations to enable maintenance work be carried out safely on the client specified Sea Chests.
2. General Visual and Close Visual Inspections of the Hull and Its appendages using an ROV.
3. Inspection and Angle Measurements of Mooring Chains.
4. Isolation of underwater penetrations (Draft Gauge Sea Water Inlet) for maintenance work to be carried out.
5. Isolation of underwater discharge lines (Boiler Blowdown) for maintenance work to be carried out.
6. Impressed Current Cathodic Protection (ICCP) Surveys.

Our Clients

1. Puma Energy
2. Zen Petroleum
3. Goil
4. Quantum Terminals
5. Total
6. Vivo/Shell
7. Matrix Ghana
8. Petrosol
9. Tema Fuel Company
10. Vana Energy
11. Stargas
12. Trade Cross
13. Annandale Gas Ghana
14. Trinity Gas
15. Sahara Group
16. GTS Trailer
17. BOST
18. Tema Oil Refinery (TOR)
19. METKA
20. IBISTEK
21. Tullow Oil
22. PSB Oil & Gas
23. Partnership with Association of Oil Marketing Companies (AOMC)
24. Partnership with Chamber of Bulk Oil Distributors (CBOD)



We Distribute
Efficient Systems
for Energy Supply





● **Innovative Engineering**

2nd Floor, Nako House, Sir Emmanuel
Quist Street, Dzorwulu, Accra
P. O. Box KD 816, Kanda, Accra
+233 23 378 0404 / +233 24 980 1676
www.starkenergyghana.com
info@starkenergyghana.com

